

ANALYSERS CALIBRATION

**CROMATOGRAPH. / DISTILLATION / RVP / ULTRA LOW SULFUR /
ASTM D OCTANE / NIR CHEMOMETRIC / FLASH POINT .**

- Calibration standard chamber is a piston floating cylinder to suit with split phase products, no contact between standard and motive fluid.
- Simplifies the ASTM D2885 calibration procedure for analysers blend certification
- Patented double piston barrier with anti-oxidant inter-seals chamber to prevent any source of leak / weathering / oxidation and keep full standard integrity .
- No vapor and VSC's losses / bubble / flash / Nitrogen blanket off-gasing .
- Accepts oxygenates or other octane enhancers, prevents any source of ON change.
- Cylinder wall autocleaning by piston scraper: prevents residuals wall adhering.
- All wetted parts in 316 L S.S. polished to 0.2 μm Ra and PTFE, no soldered seams.
- Closed level indicator preventing fuel from light exposure.
- Optional:
- European Pressure Equipment Directive PED 97/23/CE mark.
- Continuous stirring within ISO 3171 prevents stratification and keeps homogeneity.
- Level transmitter ATEX II 2 G EExi IIC T6 for remote monitoring.
- Low level trip alarm ATEX IIG EEx ed IIC T6
- Unopened standard fuel portable cylinder system for standard candidate validation.
- Additive injection special fitting
- Water traces detector on standard chamber bottom: water accumulation alarm.

2- BENEFITS OF PISTON FLOATING CYLINDER :

Quantity of worldwide releases published in oil refinery and petrochemical established the superiority of piston cylinders over the nitrogen sky tanks , the siphon cylinders and the membrane accumulators : only the results obtained with piston cylinders are in full correlation with actual composition of calibration standard .

Main difficulty is due to coexistence between gaseous and liquid phases in equilibrium in the cylinder when the boiling point of different fractions is different and the figure here under represents the multiphase envelop of a typical hydrocarbon mixture from Methane to n-Nonane .

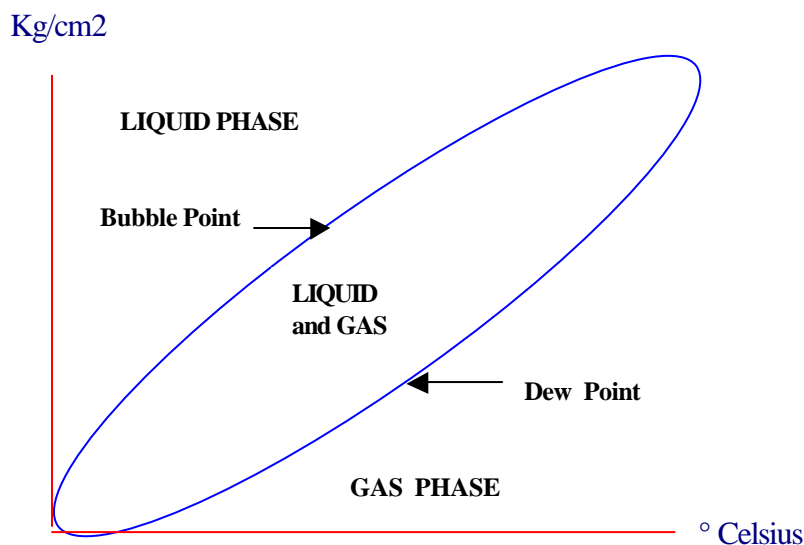

3- DESCRIPTIVE :

- Piston floating cylinder with patented double barrier and inter-seals separation chamber: this chamber can be either vented to atmosphere (double block and bleed operation) or filled with separation neutral fluid such as Nitrogen or Helium through the drilled piston shaft (neutral anti-oxidant inter-seal).
- .If no separation fluid or atmosphere reference is required the inter-seals chamber is plugged (double block operation).

This arrangement prevents any source of leak with deterioration of standard sample.

- Parts in contact with standard sample: 316L stainless steel body and PTFE seals .
- Graduated closed level indicator preventing standard sample from light exposure.

OPTIONS :

Compliance with European Pressure Equipment Directive PED 97/23/CE :

- Procedure complying with PED Annex III-Module A. Integrated relief valves LLOYD'S REGISTER certified on gas chamber. Maximum allowable pressure depends on vapor pressure of sample at maximum temperature. When vapor pressure is not greater than 0.5 bar above atmospheric pressure, relief valve is typically set at 10 bar g (please check on application basis).
- Declaration of conformity and CE mark.

Stirring devices :

- pneumatic / magnetic stirrer for standard fluid viscosity under 20 cSt
- motorised stirrer for viscosity up to 5 000 cSt or when compliance with ISO 3171 is required: ex-proof motor ATEX II 2 G EExdIICT4, 1ph. 115/230 V- 50/60 Hz-200 W.

Level transmitter :

- For remote monitoring of sample contained inside of calibration standard contained, the position of the floating piston in the cylinder is monitored by a resistive displacement level transmitter (0 to 10 Kohms) tied to the piston shaft . No calibration is required within the life of this component.
- Associated to the Intrinsically Safe Barrier KFD2-PT2-Ex1 from Pepperl + Fuchs for a 4 - 20 MA or 0-10 V DC output , the transmitter loop is certified ATEX II 2 G EExi IICT6 for hazardous area .

Low level trip alarm:

- Pre-alarm and / or low level alarm by electrical contact ATEX IIG EEx ed IIC T6 is available as option.

Additive injection fitting:

Special fitting consisting of elastomer septum for syringe can be used for additive injection into the Sample Standard candidate or to add a known amount of component of interest (Sulfur species).

Portable cylinder handling assembly for Sample Standard calibration:

Once the storage tank has been filled with the sample standard candidate a sample must be drawn in a close cylinder for analyse and validation of this product as comparison reference .

For this critical step of Sample Standard storage & validation operation the unopened portable cylinder handling assembly featuring hoses and quick connect couplings as well as disposal drain is advised.

The whole system engineered for this application and field proved is integrated as option to the calibration cylinder.



Water traces detector:

This is a microwaves propagation velocity monitor fitted on sample standard chamber bottom to detect trace of water mainly during fuel standard collection .

4 – OPERATION :

a) Cylinder filling :

If the fluid is coming under pressure from the process line , the motive air or Nitrogen in upper chamber must exceed the vapor pressure of standard sample at the maximum ambient temperature .

The same circuit is used for cylinder filling and injection of the standard sample into the analyzer .It is recommended to filter sample at 5 μm before filling the cylinder.

If the sample comes from laboratory, the most reliable way to keep standard integrity is to fill cylinder with standard by using a hand pump or similar device.

Once filling has been completed, a grab sample is taken-off for laboratory analysis.

Special fitting consisting of elastomer septum for syringe can be used for this operation.

If required, the same fitting can be employed to add a known amount of component of interest (e.g. C4 addition to Gasoline for RVP or Sulfur species for ULS measurement).

b) Inter-seals chamber processing :

The inter-seal chamber can be sealed if the plug of the piston drilled shaft is not removed (double block operation) or vented to atmosphere by removing plug and connecting a hose to drain (double block and bleed operation) .

It is also possible to fill the inter-seal chamber with neutral fluid (neutral anti-oxidant inter-seal) for instance the inter-seal chamber should be filled with Helium if the standard fluid is injected to a Nitrogen trace analyzer in gasoline .In order to reduce the neutral fluid consumption ,low pressure in the inter-seals chamber can be controller (typically at 5 mbar) .

c) Standard introduction :

Before of calibration operator must be sure that enough standard is contained in the sample chamber. A level indicator is furnished for manual calibration, for auto-cal either the level transmitter or low trip alarm option is recommended.

If the stirring device has been supplied, it must be started by air or electrical operation (depending of type) at least 20 min prior of calibration (in fact stirrer can be continuously operated as air or electrical energy required is small) . If the standard is not a pure product, stirring is recommended to avoid gravimetric separation and prevent stratification.

The starting air motor must be fed with low pressure compressed air , typically at 100 to 300 mbar . This can be achieved by using a needle valve at the outlet of pressure regulator (not included in the basic scope of supply).

The motive air or Nitrogen pressure must exceed the vapor pressure of the standard sample but must stay under the maximum pressure authorised by the analyzer manufacturer , e.g.: maximum injection valve pressure in case of a chromatograph .

5- SPECIFICATIONS :

- Standard chamber capacity: to select in the range of : 10 - 25 - 50 - 300 - 600 - 1000 dm³
- Fluid motor pressure: up to 20 bars (or as standard 10 bars if compliance with PED 97/23/CE is required)
- Design pressure: 30 bars (check maximum allowable pressure in case of PED option)
- Hydrostatic test: 20 bars during 20 min on standard sample chamber (check in case of PED option).
- Pneumatic test: 20 bars during 120 min on air or Nitrogen standard chamber (check in case of PED option).
- Material : All wetted parts in. 316 L stainless steel and PTFE .

6 – INTEGRATION :

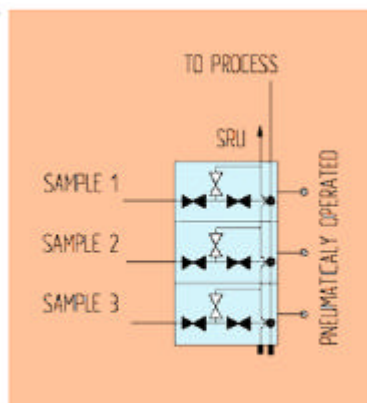

DOUBLE BLOCK & BLEED VALVES

When required , material can be supplied with sampling system integrated on free standing frame or in cabinet .

Specific components such as integrated double block & bleed pneumatic valves are provided for auto-cal on the integrated systems to prevent cross contamination and eliminate dead volumes .

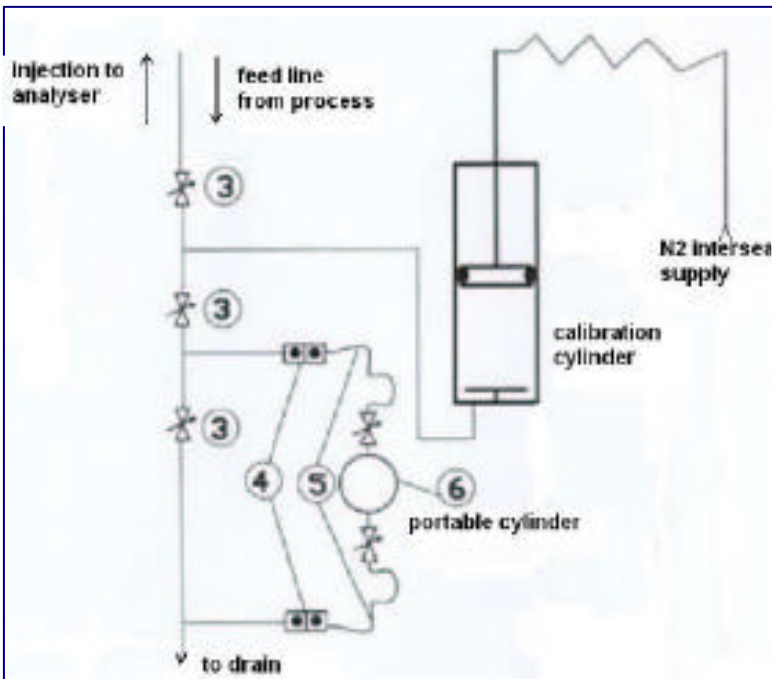
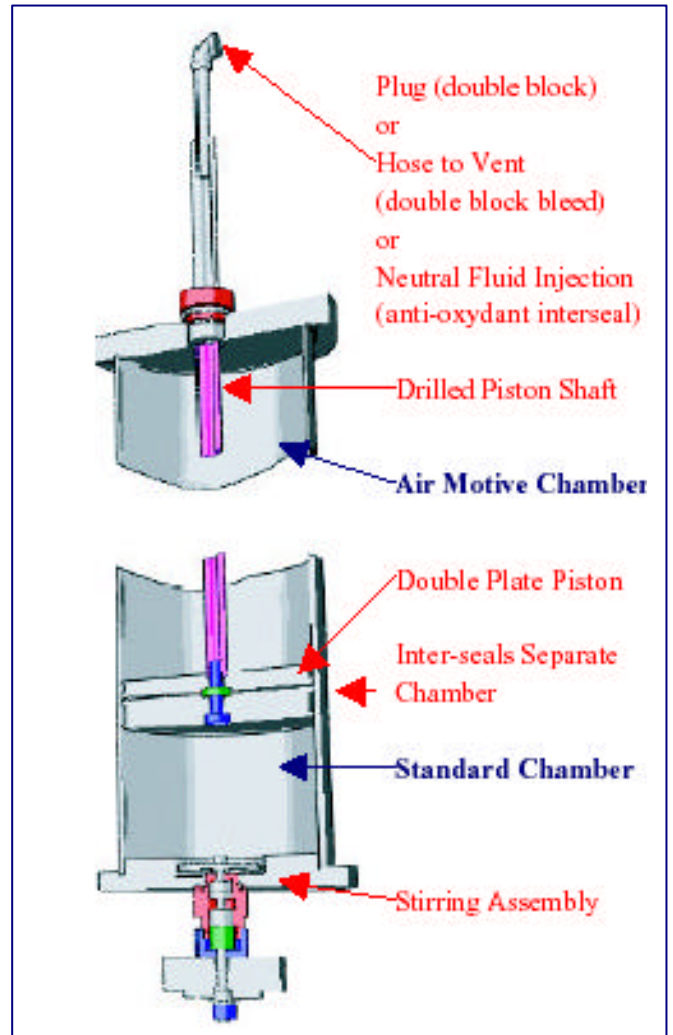
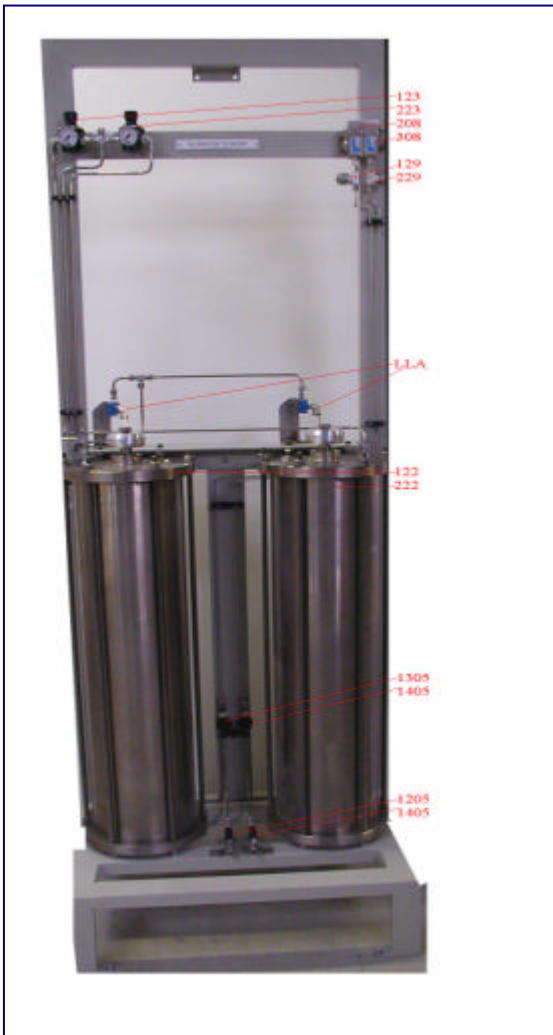

This fluid diagram represents the calibration cylinder systems featuring:

- . Inlet/outlet single line for filling from process and rejection to analyser
- . The Nitrogen inter-seal supply with PTFE hose.
- . The unopened grab fuel portable cylinder option: this is a polished to 0.2µRA receptacle for analyse and validation of the fuel stored candidate. This integrated system features hoses and quick connect couplings.
- . Under some circumstances an elastomer septum fitting for syringe is used to add a known amount of component of interest in the candidate validation fluid.

7 - VIEW :

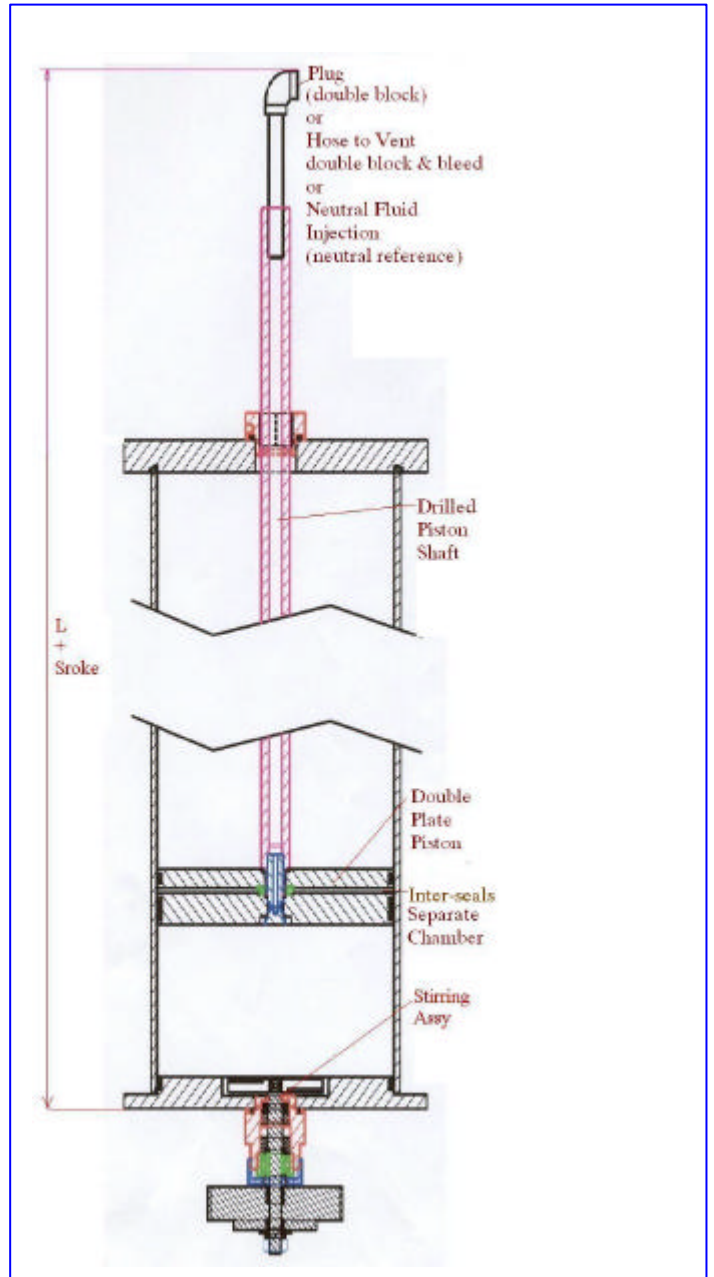

- 1- Level Trip Alarm
- 2- Piston Shaft
- 3- PED Relief Valve
- 4- Pneumatic/Magnetic Stirrer
- 5- Level Indicator

Capacitance dm3	10	25	50	300
L + Stroke mm	899	1720	600	1685
Stroke mm	365	765	190	684



8 Av. de Bretteville – 92 200 – NEULLY sur SEINE – FRANCE
 Tel : 33 (0)6 85 43 82 78 – Fax : 33 (0)6 07 18 28 07
 e-mail : barere.opta@wanadoo.fr